

GENSET MODEL
SGP 1250P / 1375S

STERLING
GENERATORS (P) LTD
(A Shapoorji Pallonji Company)

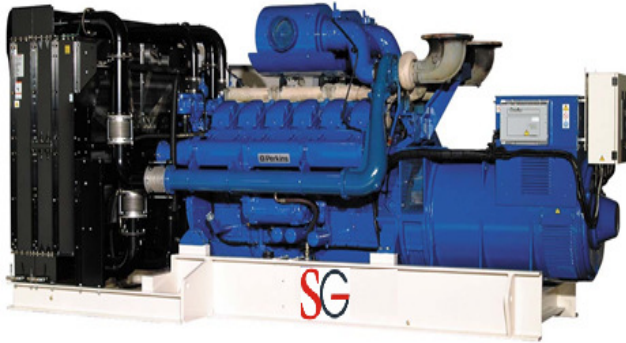

Powered by



ENGINE MODEL : 4012-46TAG0A

ALTERNATOR : Leroysoner / Stamford

GENSET RATING (Radiator/HE Cooled)

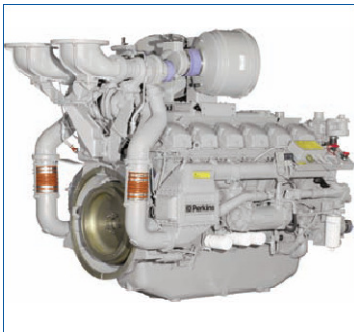

Prime - kVA/kWe

Standby - kVA/kWe

50 HZ

1250/1000

1375/1100

FEATURES

The 4012-46TAG0A is a turbocharged and air-to-air chargecooled, 12 cylinder diesel engine. Its premium feature provides economic and durable power resulting in exceptional fuel consumption, low emissions and single step block load acceptance

The 4000 Series has been developed using the latest engineering techniques and addresses today's uncompromising demands of the Power Generation industry. Developed from the proven heavy duty industrial base these products offer superior performance and reliability

Perkins Diesel Engines

Perkins history dates back to 1930's
Headquartered in Peterborough, UK
Greater than 2 Billion GBP in sales in 2008
More than 375,000 engines produced annually
Perkins is part of Caterpillar Enterprise worldwide

About Sterling Generators

A Shapoorji Pallonji Company
One of the largest integrated genset manufacturing facility in Asia with separate EOU & DTA unit
Facilities to test upto 3000 kW on 415V, 3.3 kV, 6.6 kV & 11 kV
Inhouse acoustic enclosure and control panel (LT/HT/C&R) manufacturing
Nationwide installation and network for Sales and Support

Rating Definitions

Performance based on ISO 8528/1, ISO 3046/1, BS 5000

Prime Power : Variable load not exceeding 80%. Overload of 10% permitted for 1 hour in every 12 hour of operation

Perkins Powered Sterling Gensets

Sterling provides the range of Perkins powered gensets which are recognized globally
Gensets are designed and tested as per Perkins guidelines
Single window responsibility for Sales, Service and Spares
Genset warranty : Standard 1 year with Unlimited hours of operation

Standby Power : 80% load factor with a maximum of 500 hours running per year



ISO 9001:2000

SGP-1250P / 1375S

ENGINE TECHNICAL SPECIFICATIONS

Description	Units	50 HZ	
Manufacturer		Perkins-4012-46TAG1A	
Type		Turbocharged, air-to-air charge cooling	
Cylinder arrangement	Vee	12	
Displacement	Litres	45.8	
Bore and stroke	MM	160 X 190	
Compression ratio	Ratio	13.6 : 1	
Rated speed	RPM	1500	
Altitude capability above MSL	Mtrs	1500	
Lube oil & filter change period	Hours	500	
Minimum continuous load	%	20	
Piston speed	Mtrs/Sec	9.5	
Engine kW at rated RPM	kW (HP)	1212 kW (1625HP)	
Fuel stop power as per ISO-3046	kW (HP)	1327 kW (1780 HP)	
Frequency regulation, steady state	%	+/- 0.25	
BMEP	kPa	2110	
Governor type	-	Electronic, Isochronous (Droop adjustable to 4%)	
Governor class	-	ISO 3046-4 Class A1	
Engine overspeed shutdown	RPM	1800	
Exhaust System			
Exhaust gas flow	m ³ /min	280	
Exhaust gas temperature	Deg C	425	
Exhaust back pressure - Max	kPa	5	
Exhaust outlet size - Internal	mm	2 X 254	
Fuel System			
Type of Injection		Combined Unit Injectors	
Injection Pressure	Bar	1400	
Lift pump	Type	Gear Driven	
Lift pump delivery flow	LPH	1020	
Lift pump delivery pressure	kPa	300	
Maximum suction head at pump inlet	Mtrs	2.5	
Fuel filter filtration capacity	Microns	10	
Heat retained in engine return fuel to day tank	kW	8	
Lube Oil System			
Total System Capacity	Litres	177	
Lube oil pressure - at rated speed	kPa	400	
Nominal lube oil pressure - Minimum	kPa	340	
Lube oil flow rate	LPS	6	
Normal Lube oil temperature	Deg C	105	
Recommended oil grade		API-CH4	
Heat Balance @ 100% Load			
Energy to Exhaust	kW	1015	
Energy to Coolant and Oil	kW	457	
Energy to radiation	kW	96	
Energy to Charge air cooler	kW	301	
Overall Thermal efficiency (nett)	%	41.5	
Mechanical efficiency	%	91	
Combustion/Air Intake			
Combustion air flow	m ³ /min	112	
Boost pressure ratio		2.93	
Max air restriction with clean filter	kPa	2 kpa	
Max air restriction with dirty filter	kPa	4 kpa	
Air filter	Type	Dry Paper element - 2 Nos	
Coolant System			
Total system capacity	Litres	210	
Maximum pressure in jacket water	kPa	170	
Maximum top tank temperature	Deg C	98	
Thermostat operating temperature	Deg C	71 to 85	
Coolant flow	LPM	1020.0	
Radiator Fan power	kWm	64.0	
Radiator Fan air flow (200 Pa duct Allowance)	m ³ /min	1944	
Radiator ambient capability	Deg C	50	
Recommended coolant		Perkins extended life coolant	
Radiator pressure cap setting (Minimum)	kPa	70	
Engine electrical system			
Type		24V negative earth	
Charging alternator volts / Current	VDC / Amps	28 / 40	
Starter power	kW	16.4	
Consumptions		Litres per Hour	
		SFC	Radiator
			HEC
Fuel consumption @ 100%	Gms/kWh / LPH	196	277
Fuel consumption @ 75%	Gms/kWh / LPH	195	211
Fuel consumption @ 50%	Gms/kWh / LPH	204	152
Lube oil consumption	Gms/kWh	0.52	
Specific gravity of fuel considered - 850 gms/Litre		Tolerance of +5% applicable for the above consumptions as per BS-5514/ISO-3046	

SGP-1250P / 1375S

Genset Controllers

SGDS-C2



SGDS-C3

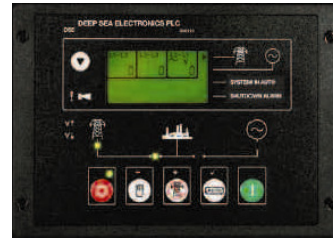

SGDS-C1 : AMF Controller (Standard Supply)

Features:

- Auto Start /Stop.
- Local & Remote Start/Stop
- Genset Breaker and Mains Breaker Control.
- Easy accessible.
- Modbus for BMS connectivity.

Display

- Engine Parameters.** - RPM, Oil Pressure, Coolant Temperature, Hour Meter, Battery Volts, Battery Charging Voltage Running Status.
- Event Recording.
- Fault Code display.

Electrical Parameters

- Voltage, Current, Hz, KW, KVA, Pf, kWh and KVAr.
Breaker Status.

Engine Protection

- High Water Temperature
- Low Lube oil Pressure
- Engine overspeed shutdown

Electrical Protection

- kW Overload
- Unbalanced Load
- Under/Over Frequency
- Under/Over Voltage

SGDS-C2 Automatic Genset Controller (Optional).

Features:

- AMF & Synchronising Controller
- Synchronising up to 16 Genset each with individual controller
- Momentarily Mains paralleling
- Auto load sharing
- Load dependent start /stop
- Load limiting Device
- Need based Priority change over / power management (Programmable)
- Genset Breaker and Mains Breaker Controller
- Auto Start / Stop

- Local & Remote Start/Stop

- Modbus for BMS connectivity

- Engine ECU diagnostics via CAN interface

Display

Engine parameters

- RPM, Engine Oil Pressure, Coolant Temperature, Battery Volts, Hour Meter
Battery Charging Volts, Fuel Level, No. of Start Attempts,
Event Recording , Fault code display, Running status

Electrical parameters

- Voltage, Current, Frequency, kVA Total, kW Total, PF, kWh, kVAr,
Phase sequence, Synchroscope display, Bus Volts, Bus Frequency, Bus phase sequ
Breaker status

Protection

Engine protection

- High Water Temperature, Low Lube oil Pressure, Engine Overspeed, Warning &
Shutdown for High Battery voltage and current, Crank failure,

Electrical protection

- Under voltage / over voltage (27/59)
- Under frequency/ over frequency (81)
- Reverse power (active and re-active) (32)
- Over Current (2 Level) (51)
- Loss of excitation (40)
- Negative Phase sequence
- Generator phase sequence
- Generator Earth fault
- Current unbalance (46)
- ROCOF/Vector shift
- Sync fail

SGP-1250P / 1375S

Sterling Standard Scope of Supply	OPTIONALS
Basic Engine Cylinder block Flywheel housing - SAE 00 High inertia flywheel - SAE J620 size 18 Oil pan Forged crankshaft Forged connecting rods Four-valve per cylinder, Individual cylinder head Aluminium Pistons Piston cooling via oil spray nozzle Dry exhaust manifolds Vibration damper Mounted air filter All necessary on-engine air, exhaust, coolant, fuel and oil pipework	Engine Jacket water heater - 110V/240V Lube oil heaters Dual electric starters Critical Silencers Additional Manuals
Starting System Electric starter Battery charging alternator, V-belt driven Battery, Battery stand & Leads Engine wiring harness and sensors	Control Panel Standard Breaker Panels Remote Annunciators AMF Panel Auto/Manual Synchronising Panel Auto Load Sharing/Load dependant Panel IP 54/55 Enclosure Isolator Panel Project Specific/Custom built Panels H T Panels for 1000 kVa & above ratings L T Distribution Boards PCC/MCC Panels PLC Panels
Fuel System Combined unit Injectors Heinzman Digital Governor and Pandaros actuator mounted on engine Governing to ISO 8528-5 class G3 with isochronous capability Replaceable fuel filter elements with primary filter and water separator Fuel Cooler	Alternator Space Heaters RTD/BTD with Scanners Oversized alternator IP 54/55 Enclosure HT Alternators - 1000 kVA & above PMG Differential CT mounted on alternator Different cooling options
Lube Oil System Lube oil circulation pump with safety valve Lube oil filter Lube oil cooler Oil filler neck and oil dipstick for measurement Open crankcase venting system	Others Acoustic enclosures - For 1010 kVA and above Additional Spare Parts Manuals Additional O&M Manuals Ni-cad Starting Batteries & Chargers Fuel level sensors Lube Oil Priming Pump - Electric/Manual Heavy Duty Air Cleaners Soot Arrestors Exhaust Scrubbers Containerized Gensets Duplex fuel filters Multi spring vibration Isolators DG Sets for special applications
Combustion Air System Exhaust turbocharger Air-air-cooler - Inbuilt with radiator Exhaust flexible bellows - 2 nos. Exhaust Silencers - Residential Air filter with contamination indicator	SGDS Controllers SGDS-C1 Controller - Digital display module SGDS-C3 Controller - Auto Sync Module SGDS-C4 Mains Controller - For Grid Paralleling PLC based load management system
Cooling System Gear driven coolant pump Belt driven fan Radiator with Fan, fan drive and fan guard	
Engine Mounting Front engine mounting bracket Resilient engine mounts (Rubber Elements) on engine free end and driving end Alternator mounts (Rubber Elements) (AVM between eng/alt and base frame)	
Genset Management System - SGDS-C2 (Supplied as standard) Electronic controller for indicating genset parameters Emergency stop push button Genset monitoring and display of Engine-alternator operating parameters and alarms Genset protection against critical operating parameters - Automatic start sequence control - Acquisition and display of plant-related measuring data - Communication with an external system	
Generator 415 Volts, 50 HZ, 1500 RPM, 4 pole, Single BEARING, 3 phase connected with IP23 protection. Alternator conforms to IS-4722 or equivalent	
Paintwork Standard paintwork, single-coat, water-based	
Documentation Standard Factory test report Engine alternator test certificate Warranty certificate Set of standard operating and maintenance documentation & Spare parts manual	

SGP-1250P / 1375S

WEIGHT	11000 KG.(APPROX.)	
6	AVM	---
5	FUEL PRE FILTER	SEPAR
4	RADIATOR	PERKINS
3	ALTERNATOR	LSC 74M1
2	ENGINE	PERKINS 4012-40 (AG PART NO. 21NETS)
1	BASE FRAME	50PL
PART NO.	DESCRIPTION	MAKE/MODEL

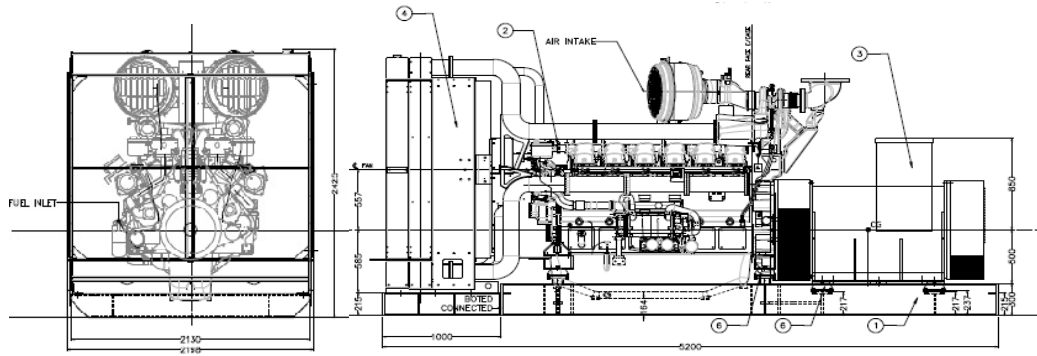

Acoustic Enclosure		STD 40 Foot Container for Export	
Length	8500	Length	12192
Width	2400	Width	2438
Height	3800	Height	2591
Weight in Kgs (Wet)	12800(apprx.)	Weight in Kgs (Wet)	17500(apprx.)

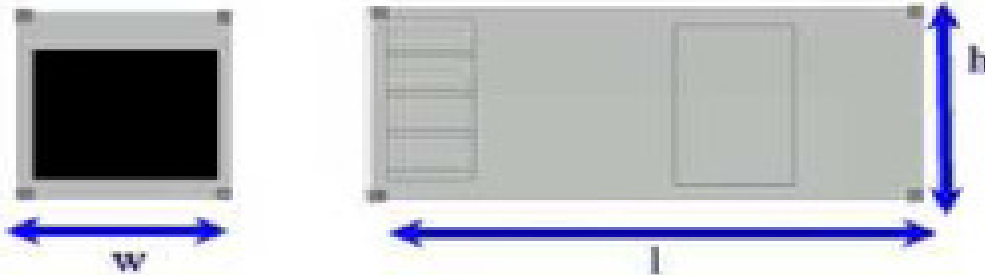

Head Quarters Sterling & Wilson Powergen (P) Ltd., 8, Sundaram Estate Govandi Station Road Govandi East Mumbai - 400 088 Tel : 022 - 2552 6100 Fax : 022 - 2552 6200 Website: www.sterlinggenerators.com	Works Sterling Generators (P) Ltd., Survey No. 59, 343/1 Village kala, Kherdi, Khanvel Silvassa 396230 U.T. of Dadra & Nagar Haveli Tel : 0260 - 2677408 / 419 Fax : 0260 - 2677408 E-Mail : silvassa@sterlinggenerators.com
---	---

Marketing & Support offices			
Zonal Office - South Sterling & Wilson Powergen (P) Ltd., Sterling Towers, No. 4A/14, 4th Main Road, Chikka Adugodi New Layout Tavarekere Main Road, Bangalore - 560 029 Tel : 080 - 67178600 - 609 Fax : 080 - 67178675	Zonal Office - North Sterling & Wilson Powergen (P) Ltd., Sterling & Wilson House, C-56/38, Institutional Area, Sector 68, Noida - UP Tel : 0120 - 407 1000 Fax : 0120 - 407 1030	Zonal Office - East Sterling & Wilson Powergen (P) Ltd., BF - 164, Sector 1, Salt Lake City, Kolkata - 700 064 Tel : 033 - 2337 3933 Fax : 033 - 4005 5416	Zonal Office - West Sterling & Wilson Powergen (P) Ltd., 8, Sundaram Estate Govandi Station Road Govandi East Mumbai - 400 088 Tel : 022 - 2552 6100 Fax : 022 - 2552 6200

BRANCH			
Hyderabad Chennai Coimbatore	Jaipur Chandigarh	Bhubaneswar	Baroda Pune

Authorized Dealer

Technical specifications are subject to change from time to time due to Design improvements without notice

July 2009