

GENSET MODEL
SGM 2350PH / 2575SH

STERLING
GENERATORS (P) LTD
(A Shapoorji Pallonji Company)



Powered by



ENGINE MODEL : 16V4000G63

ALTERNATOR : LeroySommer / Stamford

GENSET RATING with HE Cooled

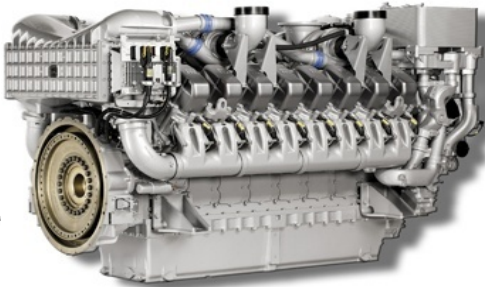

Prime - kVA/kWe

Standby - kVA/kWe

50 HZ

2350/1880

2575/2060

FEATURES

MTU Diesel Engines

MTU history dates back to 19th century
Headquartered in Friedrichshafen, Germany
Global presence with superior technology
Wholly owned subsidiary of Daimler-Chrysler until 2006
Now part of TOGNUM group

The MTU 4000 series diesel engines are turbocharged and Air-to-Water charge cooled, 16 cylinder 'V-90°' configuration. Their premium features like full authority electronics are achieved by complete digital electronic governor (ADEC). Proven Common Rail Direct Injection (CRDI), Electronically controlled unit fuel injection system provides economic and durable power resulting in exceptional fuel consumption, low emissions meeting global norms and single step block load acceptance.

About Sterling Generators

A Shapoorji Pallonji Company
One of the **largest integrated genset manufacturing facility** in Asia with separate EOU & DTA unit
Facilities to test upto 3000 kW on 415V, 3.3 kV, 6.6 kV & 11 kV
Inhouse acoustic enclosure and control panel (LT/HT/C&R) manufacturing
Nationwide installation and network for Sales and Support

Rating Definitions

Performance based on ISO 8528/1, ISO 3046/1, BS 5000

MTU Powered Sterling Gensets

Sterling provides the range of MTU powered gensets which are recognized globally for reliability, better efficiency and eco-friendliness
Gensets are designed and tested as per MTU guidelines
Single window responsibility for Sales, Service and Spares
Genset Warranty : Standard 1 year with Unlimited hours of operation

Prime Power : Variable load not exceeding 75%. Overload of 10% permitted for 1 hour in every 12 hour of operation

Standby Power : 85% load factor with a maximum of 500 hours running per year



ISO 9001:2000

SGM-2350PH / 2575SH

ENGINE TECHNICAL SPECIFICATIONS

Description	Units	50 HZ
Manufacturer		
Type		MTU 162V4000G63
Cylinder arrangement	Vee	Turbocharged, Air-to-Water cooling
Displacement	Litres	16
Bore and stroke	MM	76.3
Compression ratio	Ratio	170 X 210
Rated speed	RPM	16.5 : 1
Altitude capability above MSL	Mtrs	1500
Lube oil & filter change period	Hours	1500
Minimum continuous load	%	500
Piston speed	Mtrs/Sec	20
Engine kW at rated RPM	kW (HP)	10.5
Fuel stop power as per ISO-3046	kW (HP)	1965 kW (2634 HP)
Frequency regulation, steady state	%	2162 kW (2898 HP)
BMEP	kPa	+/- 0.25
Governor type	-	2060
Governor class	-	Electronic, Isochronous (Droop adjustable to 4%)
Engine overspeed shutdown	RPM	ISO 8528-5, better than Class A1
		1800
Exhaust System		
Exhaust gas flow	m ³ /min	348
Exhaust gas temperature	Deg C	485
Exhaust back pressure - Design value/Maximum	mbar	30/85
Fuel System		
Type of injection		CRDI with Electronic Unit Injection
Fuel supply flow - Max	LPM	14/6
Fuel temperature at fuel inlet - Max	Deg C	55
Fuel pressure at return - Max	Bar	0.5
Maximum suction head at pump inlet	Mtrs	2.5
Fuel filter filtration capacity - Secondary	Microns	5
Fuel filter pressure differential - Max	Bar	1
Lube Oil System		
Total system capacity	Litres	300
Normal lube oil pressure	Bar	5
Normal lube oil temperature	Deg C	89 - 95
Lube oil differential pressure	Bar	1.5
Lube oil filter filtration capacity	Microns	12
Recommended lube oil grade		API-CI4
Heat Balance @ 100% Load		
Energy to coolant	kW	730
Energy to charge air cooler	kW	320
Energy to radiation	kW	90
Combustion/Air Intake		
Combustion air flow	m ³ /min	138
Charge air pressure	Bar	2.8
Air filter	Type	Dry paper type - 4 Nos.
Coolant System		
Total system capacity	Litres	225+200
Cooling sytem operating pressure	Bar	2.5
Normal Coolant temperature - HT/LT	Deg C	100/55
Coolant flow - HT/LT	m ³ /Hr	68.5/30
Coolant pump inlet pressure - Min/Max	Bar	0.2/1.5
Cooling system ambient capability	Deg C	50
Recommended coolant		MTU extended life coolant
Engine Electrical System		
Type		24V negative earth
Charging alternator volts / Current	VDC / Amps	28 / 70
Starter power	kW	2X9

SGM-2350PH / 2575SH

Genset Controllers

SGDF-C2



SGDF-C3



SGDF-C2 : AMF Controller (Standard Supply)

Features:

- Auto Start /Stop.
- Local & Remote Start/Stop
- Engine Parameters Reading via CANBUS.
- Genset Breaker and Mains Breaker Control.
- Easily accessible.
- MODBUS for BMS connectivity.

Display

- Engine Parameters
- Running Status
- Event Recording
- Fault Code Display
- Hourmeter
- Voltage, Current, Hz, KW, KVA, Pf and KVAR
- Breaker Status
- Service Timer Indication
- Real Time Clock for Time and Date

Protection

- Under Voltage / Over Voltage
- Under Frequency / Over Frequency
- Reverse Power
- Over Current
- Engine Protections

SGDF-C3 Automatic Genset Controller (Optional).

Features:

- AMF & Synchronising Controller
- Synchronising up to 16 Genset each with individual controller
- Momentarily Mains paralleling
- Auto load sharing
- Load dependent start /stop
- Load limiting Device
- Mains power export
- Simple Logic configuration tool
- Need based Priority change over / power management (Programmable)
- Genset Breaker and Mains Breaker Controller
- Auto Start / Stop
- Local & Remote Start/Stop
- Eng. parameters & protections reading via CAN bus
- Easy accessibility
- Modbus for BMS connectivity
- Utility software for PC interface
- Grid Paralleling (**SGDF-C4 mains Optional**)

Display

- Engine parameters
- Running Status
- Event Recording
- Fault Code display
- Service Timer Indication
- Hour Meter, Real Time Clock for time and Date
- Voltage, Current, Hz, KW, KVA, Pf and KVAR
- Breaker Status
- Synchronous Scope

Protection

- Engine Protections
- Under voltage / over voltage (27/59)
- Under frequency/ over frequency (81)
- Reverse power (active and re-active) (32)
- Over Current (2 Level) (51)
- Peak Current (50)
- Loss of excitation (40)
- Current unbalance (46)
- Voltage asymmetry (47)

SGM-2350PH / 2575SH

Sterling Standard Scope of Supply	OPTIONALS
Basic Engine Cylinder block Flywheel housing - SAE 00 High inertia flywheel - SAE 21 Oil pan Forged crankshaft & connecting rods Valve rotators (Rotocap) Four-valve per cylinder, Individual cylinder head Aluminium Pistons Piston cooling via oil spray nozzle Dry exhaust manifolds Vibration damper Mounted air filter All necessary on-engine air, exhaust, coolant, fuel and oil pipework	Engine Jacket water heater - 110V/240V Lube oil heaters Dual electric starters Critical Silencers Additional Manuals
Starting System Electric starter, dual Battery charging alternator, V-belt driven - 28VDC, 100 A, 2 pole Battery, Battery stand & Leads Engine wiring harness and sensors	Control Panel Standard Breaker Panels Remote Annunciators AMF Panel Auto/Manual Synchronising Panel Auto Load Sharing/Load dependant Panel IP 54/55 Enclosure Isolator Panel Project Specific/Custom built Panels H T Panels for 1000 kVa & above ratings L T Distribution Boards PCC/MCC Panels PLC Panels
Fuel System CRDI fuel system with High and Low pressure pumps Electronically controlled fuel injection with high pressure lines Fuel pressure accumulator Fuel cooler Fuel priming pump for initial system filling and venting Engine standard version for fuel consumption-optimized operation Secondary Fuel Filter Fuel Water Separator	Alternator Space Heaters RTD/BTD with Scanners Oversized alternator IP 54/55 Enclosure HT Alternators - 1000 kVa & above PMG Differential CT mounted on alternator Different cooling options
Lube Oil System Forced-feed lubrication system with piston cooling Lube oil circulation pump with safety valve Lube oil multi-stage filter Lube oil heat exchanger Oil filler neck and oil dipstick for measurement on non-running engine Closed crankcase venting system	Others Cap Type Acoustic Enclosure Additional Spare Parts Manuals Additional O&M Manuals Ni-cad Starting Batteries & Chargers Fuel level sensors Lube Oil Priming Pump - Electric/Manual Heavy Duty Air Cleaners Soot Arrestors Exhaust Scrubbers Containerized Genset in 40 Feet Container Duplex fuel pre - filters Multi spring vibration Isolators
Combustion Air System Exhaust turbochargers with insulation Intercooler Exhaust flexible bellows - 2 nos. Exhaust Silencers - Residential Set of dry-type air filters with contamination indicator	
Cooling System Coolant circulation pump for jacket water and after cooler Coolant thermostat for jacket water cooling system Coolant thermostat for charge air cooling system Heat Exchanger - Plate type	
Engine Mounting Set of engine mounting brackets at engine free end and driving end Resilient engine mounts (Rubber Elements) on engine free end and driving end Alternator mounts (Rubber Elements)	Genset Controllers SGDF-C1 Controller - Digital display module SGDF-C3 Controller - Auto Sync Module SGDF-C4 Mains Controller - For Grid Paralleling PLC based load management system
Genset Management System - SGDF-C2 (Supplied as standard) Electronic controller for indicating genset parameters Emergency stop push button Genset monitoring and display of Engine-alternator operating parameters and alarms Genset protection against critical operating parameters - Automatic start sequence control - Acquisition and display of plant-related measuring data - Communication with an external system	
Generator 415 Volts, 50 HZ, 1500 RPM, 4 pole, Single BEARING, 3 phase connected with IP23 protection. Alternator conforms to IS-4722 or equivalent	
Paintwork Standard paintwork, single-coat, water-based	
Documentation Standard Factory test report Engine alternator test certificate Warranty certificate Set of standard operating and maintenance documentation & Spare parts manual	

SGM-2350PH / 2575SH

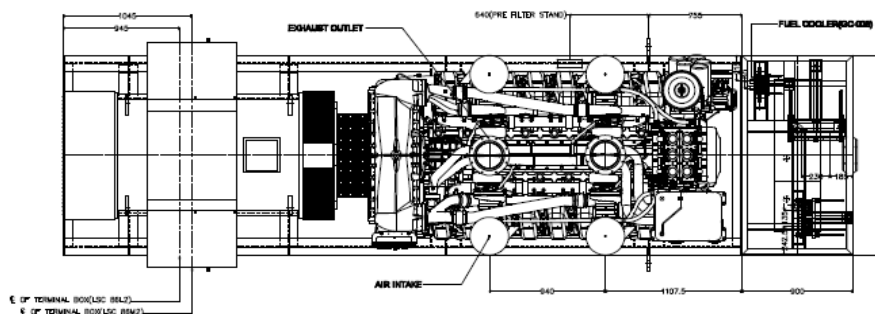

TOP VIEW

WEIGHT(STATIC)		18500 KG. (APPROX.)
7	HEAT EXCHANGER	TRANTRER
8	AVM	RESISTO FLEX CSD2 - 25/2000
6	COUPLING WITH GUARD	POONA COUPLING HTR - 10000
4	FUEL PRE-FILTER	SEPAR
3	ALTERNATOR	LSC 65M2/L2
2	ENGINE	MTU 16V 4000 G23/G63
1	BASE FRAME	6GPL
PART NO.	ITEM DESCRIPTION	MAKE/MODEL

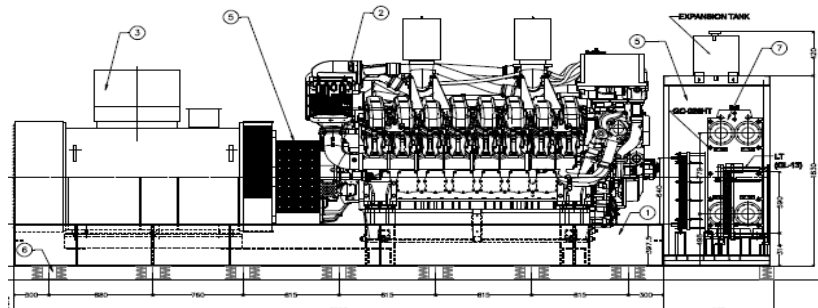

Approved Enclosure

Length	10000
Width	3500
Height	4100
Weight in Kgs (Wet)	22000(apprx.)

STD 20 Foot Container for Export

Length	6435
Width	1660
Height	2390
Weight in Kgs (Wet)	18500(apprx.)

Head Quarters

Sterling & Wilson Powergen (P) Ltd.,
8, Sundaram Estate
Govandi Station Road
Govandi East
Mumbai - 400 088
Tel : 022 - 2552 6100
Fax : 022 - 2552 6200
Website: www.sterlinggenerators.com

Works

Sterling Generators (P) Ltd.,
Survey No. 59, 343/1
Village kala, Kherdi, Khanvel
Silvassa 396230
U.T. of Dadra & Nagar Haveli
Tel : 0260 - 2677408 / 419
Fax : 0260 - 2677408
E-Mail : silvassa@sterlinggenerators.com

Marketing & Support offices

Zonal Office - South	Zonal Office - North	Zonal Office - East	Zonal Office - West
Sterling & Wilson Powergen (P) Ltd., Sterling Towers, No. 4A/14, 4th Main Road, Chikka Adugodi New Layout Tavarekere Main Road, Bangalore - 560 029 Tel : 080 - 67178600 - 609 Fax : 080 - 67178675	Sterling & Wilson Powergen (P) Ltd., Sterling & Wilson House, C-56/38, Institutional Area, Sector 68, Noida - UP Tel : 0120 - 407 1000 Fax : 0120 - 407 1030	Sterling Generators (P) Ltd., BF - 164, Sector 1, Salt Lake City, Kolkata - 700 064 Tel : 033 - 2337 3933 Fax : 033 - 4005 5416	Sterling & Wilson Powergen (P) Ltd., 8, Sundaram Estate Govandi Station Road Govandi East Mumbai - 400 088 Tel : 022 - 2552 6100 Fax : 022 - 2552 6200

BRANCHES

Hyderabad Chennai Coimbatore	Jaipur Chandigarh	Bhubaneshwar	Baroda Pune
------------------------------------	----------------------	--------------	----------------

Authorized Dealer