

**GENSET MODEL**  
**SGM 2050PR / 2250SR**

**STERLING**  
 GENERATORS (P) LTD  
*(A Shapoorji Pallonji Company)*



**Powered by**



**ENGINE MODEL : 16V4000G23**

**ALTERNATOR : Leroysoner / Stamford**

**GENSET RATING with Radiator Cooled**

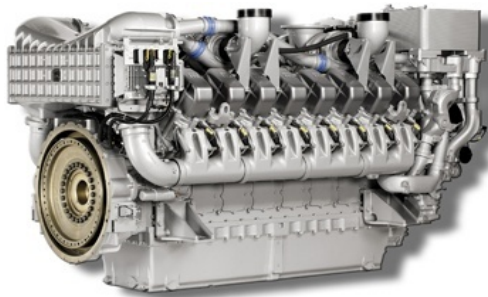

Prime - kVA/kWe

Standby - kVA/kWe

50 HZ

2050/1640

2250/1800

**FEATURES**

**MTU Diesel Engines**

MTU history dates back to 19th century  
 Headquartered in Friedrichshafen, Germany  
 Global presence with superior technology  
 Wholly owned subsidiary of Daimler-Chrysler until 2006  
 Now part of TOGNUM group

**About Sterling Generators**

A Shapoorji Pallonji Company  
 One of the **largest integrated genset manufacturing facility** in Asia with separate EOU & DTA unit  
 Facilities to test upto 3000 kW on 415V, 3.3 kV, 6.6 kV & 11 kV  
 Inhouse acoustic enclosure and control panel (LT/HT/C&R) manufacturing  
 Nationwide installation and network for Sales and Support

**MTU Powered Sterling Gensets**

Sterling provides the range of MTU powered gensets which are recognized globally for reliability, better efficiency and eco-friendliness  
 Gensets are designed and tested as per MTU guidelines  
 Single window responsibility for Sales, Service and Spares  
 Genset Warranty : Standard 1 year with Unlimited hours of operation

The MTU 4000 series diesel engines are turbocharged and Air-to-Water charge cooled, 16 cylinder 'V-90°' configuration. Their premium features like full authority electronics are achieved by complete digital electronic governor (ADEC). Proven Common Rail Direct Injection (CRDI), Electronically controlled unit fuel injection system provides economic and durable power resulting in exceptional fuel consumption, low emissions meeting global norms and single step block load acceptance.

**Rating Definitions**

Performance based on ISO 8528/1, ISO 3046/1, BS 5000

**Prime Power** : Variable load not exceeding 75%. Overload of 10% permitted for 1 hour in every 12 hour of operation

**Standby Power** : 85% load factor with a maximum of 500 hours running per year



**ISO 9001:2000**

# SGM-2050PR / 2250SR

## ENGINE TECHNICAL SPECIFICATIONS

Description	Units	50 HZ
<b>Manufacturer</b>		
Type		<b>MTU 162V4000G23</b>
Cylinder arrangement		Turbocharged, Air-to-Water cooling
Displacement	Vec	16
Bore and stroke	Litres	76.3
Compression ratio	MM	170 X 210
Rated speed	Ratio	16.5 : 1
Altitude capability above MSL	RPM	1500
Lube oil & filter change period	Mtrs	1500
Minimum continuous load	Hours	500
Piston speed	%	20
Engine kW at rated RPM	Mtrs/Sec	10.5
Fuel stop power as per ISO-3046	kW (HP)	1798 kW (2410 HP)
Frequency regulation, steady state	kW (HP)	1978 kW (2651 HP)
BMEP	%	+/- 0.25
Governor type	kPa	1890
Governor class	-	Electronic, Isochronous (Droop adjustable to 4%)
Engine overspeed shutdown	-	ISO 8528-5, better than Class G3
	RPM	1800
<b>Exhaust System</b>		
Exhaust gas flow	m3/min	324
Exhaust gas temperature	Deg C	480
Exhaust back pressure - Design value/Maximum	mbar	30/85
<b>Fuel System</b>		
Type of injection		CRDI with Electronic Unit Injection
Fuel supply flow - Max	LPM	14/6
Fuel temperature at fuel inlet - Max	Deg C	55
Fuel pressure at return - Max	Bar	0.5
Maximum suction head at pump inlet	Mtrs	2.5
Fuel filter filtration capacity - Secondary	Microns	5
Fuel filter pressure differential - Max	Bar	1
<b>Lube Oil System</b>		
Total system capacity	Litres	300
Normal lube oil pressure	Bar	5
Normal lube oil temperature	Deg C	89 - 95
Lube oil differential pressure	Bar	1.5
Lube oil filter filtration capacity	Microns	12
Recommended lube oil grade		API-C14
<b>Heat Balance @ 100% Load</b>		
Energy to coolant	kW	710
Energy to charge air cooler	kW	260
Energy to radiation	kW	90
<b>Combustion/Air Intake</b>		
Combustion air flow	m3/min	126
Charge air pressure	Bar	2.6
Air filter	Type	Dry paper type - 4 Nos.
<b>Coolant System</b>		
Total system capacity	Litres	225+200
Cooling sytem operating pressure	Bar	2.5
Coolant temperature	Deg C	100/55
Coolant flow	m3/Hr	68.5/30
Coolant pump inlet pressure - Min/Max	Bar	0.2/1.5
Radiator fan power	HP	55
Radiator fan air flow (with 200 pa duct allowance)	CFM	74800
Cooling system ambient capability	Deg C	50
Recommended coolant		MTU extended life coolant
<b>Engine Electrical System</b>		
Type		24V negative earth
Charging alternator volts / Current	VDC / Amps	28 / 70
Starter power	kW	2X9
Lube oil consumption	% of Fuel	0.3% of fuel consumption

# SGM-2050PR / 2250SR

## Genset Controllers

**SGDF-C2**



**SGDF-C3**



### SGDF-C2 : AMF Controller (Standard Supply)

**Features:**

- Auto Start /Stop.
- Local & Remote Start/Stop
- Engine Parameters Reading via CANBUS.
- Genset Breaker and Mains Breaker Control.
- Easily accessible.
- MODBUS for BMS connectivity.

**Display**

- Engine Parameters
- Running Status
- Event Recording
- Fault Code Display
- Hourmeter
- Voltage, Current, Hz, KW, KVA, Pf and KVAr
- Breaker Status
- Service Timer Indication
- Real Time Clock for Time and Date

**Protection**

- Under Voltage / Over Voltage
- Under Frequency / Over Frequency
- Reverse Power
- Over Current
- Engine Protections

### SGDF-C3 Automatic Genset Controller (Optional).

**Features:**

- AMF & Synchronising Controller
- Synchronising upto 16 Genset each with Individual Controller
- Momentarily Mains Paralleling
- Auto Load Sharing
- Load Dependent Start /Stop
- Load Limiting Device
- Mains Power Export
- Simple Logic Configuration Tool
- Need based Priority changeover / Power Management (Programmable)
- Genset Breaker and Mains Breaker Controller
- Auto Start / Stop
- Local & Remote Start/Stop
- Engine Parameters & Protections Reading via CANBUS
- Easy accessibility
- MODBUS for BMS connectivity
- Utility Software for PC interface
- Grid Paralleling (**SGDF-C4 Mains Optional**)

**Display**

- Engine Parameters
- Running Status
- Event Recording
- Fault Code Display
- Service Timer Indication
- Hour Meter, Real Time Clock for Time and Date
- Voltage, Current, Hz, KW, KVA, Pf and KVAr
- Breaker Status
- Synchronous Scope

**Protection**

- Engine Protections
- Under Voltage / Over Voltage (27/59)
- Under Frequency / Over Frequency (81)
- Reverse Power (active and re-active) (32)
- Over Current (2 Level) (51)
- Peak Current (50)
- Loss of Excitation (40)
- Current Unbalance (46)
- Voltage Asymmetry (47)

# SGM-2050PR / 2250SR

Sterling Standard Scope of Supply	OPTIONALS
<b>Basic Engine</b> Cylinder block Flywheel housing - SAE 00 High inertia flywheel - SAE 21 Oil pan Forged crankshaft & connecting rods Valve rotators (Rotocap) Four-valve per cylinder, Individual cylinder head Aluminium Pistons Piston cooling via oil spray nozzle Dry exhaust manifolds Vibration damper Mounted air filter All necessary on-engine air, exhaust, coolant, fuel and oil pipework	<b>Engine</b> Jacket water heater - 110V/240V Lube oil heaters Dual electric starters Critical Silencers Additional Manuals
<b>Starting System</b> Electric starter, dual Battery charging alternator, V-belt driven - 28VDC, 100 A, 2 pole Battery, Battery stand & Leads Engine wiring harness and sensors	<b>Control Panel</b> Standard Breaker Panels Remote Annunciators AMF Panel Auto/Manual Synchronising Panel Auto Load Sharing/Load dependant Panel IP 54/55 Enclosure Isolator Panel Project Specific/Custom built Panels H T Panels for 1000 kVa & above ratings L T Distribution Boards PCC/MCC Panels PLC Panels
<b>Fuel System</b> CRDI fuel system with High and Low pressure pumps Electronically controlled fuel injection with high pressure lines Fuel pressure accumulator Fuel cooler Fuel priming pump for initial system filling and venting Engine standard version for fuel consumption-optimized operation Secondary Fuel Filter Fuel Water Separator	<b>Alternator</b> Space Heaters RTD/BTD with Scanners Oversized alternator IP 54/55 Enclosure HT Alternators - 1000 kVA & above PMG Differential CT mounted on alternator Different cooling options
<b>Lube Oil System</b> Forced-feed lubrication system with piston cooling Lube oil circulation pump with safety valve Lube oil multi-stage filter Lube oil heat exchanger Oil filler neck and oil dipstick for measurement on non-running engine Closed crankcase venting system	<b>Others</b> Cap Type Acoustic Enclosure Additional Spare Parts Manuals Additional O&M Manuals Ni-cad Starting Batteries & Chargers Fuel level sensors Lube Oil Priming Pump - Electric/Manual Heavy Duty Air Cleaners Soot Arrestors Exhaust Scrubbers
<b>Combustion Air System</b> Exhaust turbochargers with insulation Intercooler Exhaust flexible bellows - 2 nos. Exhaust Silencers - Residential Set of dry-type air filters with contamination indicator	Containerized Genset in 40 Feet Container Duplex fuel pre - filters Multi spring vibration Isolators
<b>Cooling System</b> Coolant circulation pump for jacket water and after cooler Coolant thermostat for jacket water cooling system Coolant thermostat for charge air cooling system Electric motor driven radiator with fan and guard	<b>Genset Controllers</b> SGDF-C1 Controller - Digital display module SGDF-C3 Controller - Auto Sync Module SGDF-C4 Mains Controller - For Grid Paralleling PLC based load management system
<b>Engine Mounting</b> Set of engine mounting brackets at engine free end and driving end Resilient engine mounts (Rubber Elements) on engine free end and driving end Alternator mounts (Rubber Elements)	
<b>Genset Management System - SGDF-C2 (Supplied as standard)</b> Electronic controller for indicating genset parameters Emergency stop push button Genset monitoring and display of Engine-alternator operating parameters and alarms Genset protection against critical operating parameters - Automatic start sequence control - Acquisition and display of plant-related measuring data - Communication with an external system	
<b>Generator</b> 415 Volts, 50 HZ, 1500 RPM, 4 pole, Single BEARING, 3 phase connected with IP23 protection. Alternator confirms to IS-4722 or equivalent	
<b>Paintwork</b> Standard paintwork, single-coat, water-based	
<b>Documentation</b> Standard Factory test report Engine alternator test certificate Warranty certificate Set of standard operating and maintenance documentation & Spare parts manual	

# SGM-2050PR / 2250SR

WEIGHT(STATIC)		19000 KG. (APPROX.)
7	RADIATOR	CHEVON
6	AVM	RESISTO FLEX
5	COUPLING WITH GUARD	OSD2-25/2000
4	FUEL PRE-FILTER	POONA COUPLING
3	ALTERNATOR	HTB - 10000
2	ENGINE	SEPAR
1	BASE FRAME	LSC 86M2/L2
		MTU 16V 4000 G23/G63
		SGPL
PART NO.	ITEM DESCRIPTION	MAKE/MODEL

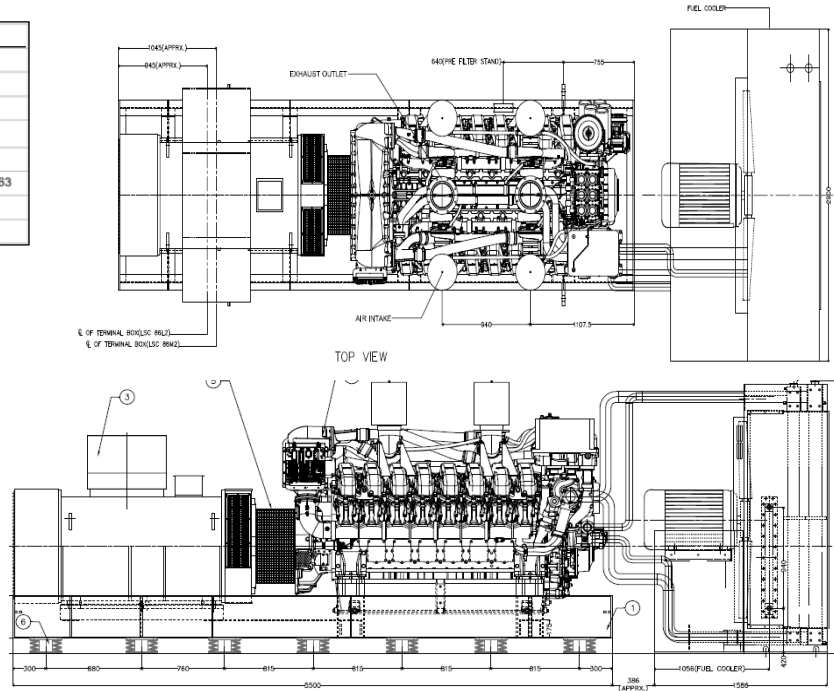

Acoustic Enclosure (Cap On Type)		STD Open Generator	
Length	10000	Length	7472
Width	3500	Width	2900
Height	4100	Height	2535
Weight in Kgs (Wet)	23500(apprx.)	Weight in Kgs (Wet)	19000(apprx.)

Head Quarters	Works
Sterling & Wilson Powergen (P) Ltd., 8, Sundaram Estate Govandi Station Road Govandi East Mumbai - 400 088 Tel : 022 - 2552 6100 Fax : 022 - 2552 6200 Website: www.sterlinggenerators.com	Sterling Generators (P) Ltd., Survey No. 59, 343/1 Village kala, Kherdi, Khanvel Silvassa 396230 U.T. of Dadra & Nagar Haveli Tel : 0260 - 2677408 / 419 Fax : 0260 - 2677408 E-Mail : silvassa@sterlinggenerators.com

### Marketing & Support offices

Zonal Office - South	Zonal Office - North	Zonal Office - East	Zonal Office - West
Sterling & Wilson Powergen (P) Ltd., Sterling Towers, No. 4A/14, 4th Main Road, Chikka Adugodi New Layout Tavarekere Main Road, Bangalore - 560 029 Tel : 080 - 67178600 - 609 Fax : 080 - 67178675	Sterling & Wilson Powergen (P) Ltd., Sterling & Wilson House, C-56/38, Institutional Area, Sector 68, Noida - UP Tel : 0120 - 407 1000 Fax : 0120 - 407 1030	Sterling Generators (P) Ltd., BF - 164, Sector 1, Salt Lake City, Kolkata - 700 064 Tel : 033 - 2337 3933 Fax : 033 - 4005 5416	Sterling & Wilson Powergen (P) Ltd., 8, Sundaram Estate Govandi Station Road Govandi East Mumbai - 400 088 Tel : 022 - 2552 6100 Fax : 022 - 2552 6200

### BRANCHES

Hyderabad Chennai Coimbatore	Jaipur Chandigarh	Bhubaneswar	Baroda Pune
------------------------------------	----------------------	-------------	----------------

### Authorized Dealer

--