

**GENSET MODEL**  
**SGM 1875PH / 2050SH**

**STERLING**  
GENERATORS (P) LTD  
*(A Shapoorji Pallonji Company)*



**Powered by**



**ENGINE MODEL : 12V4000G63**

**ALTERNATOR : LeroySommer / Stamford**

**GENSET RATING - HE Cooled**

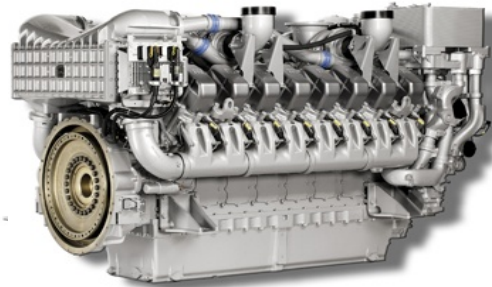

Prime - kVA/kWe

Standby - kVA/kWe

50 HZ

1875/1500

2050/1640

**FEATURES**

**MTU Diesel Engines**

MTU history dates back to 19th century  
Headquartered in Friedrichshafen, Germany  
Global presence with superior technology  
Wholly owned subsidiary of Daimler-Chrysler until 2006  
Now part of TOGNUM group

The MTU 4000 series diesel engines are turbocharged and Air-to-Water charge cooled, 12 cylinder 'V-90°' configuration. Their premium features like full authority electronics are achieved by complete digital electronic governor (ADEC). Proven Common Rail Direct Injection (CRDI), Electronically controlled unit fuel injection system provides economic and durable power resulting in exceptional fuel consumption, low emissions meeting global norms and single step block load acceptance.

**About Sterling Generators**

A Shapoorji Pallonji Company  
One of the **largest integrated genset manufacturing facility** in Asia with separate EOU & DTA unit  
Facilities to test up to 3000 kW on 415V, 3.3 kV, 6.6 kV & 11 kV  
In-house acoustic enclosure and control panel (LT/HT/C&R) manufacturing  
Nationwide installation and network for Sales and Support

**Rating Definitions**

Performance based on ISO 8528/1, ISO 3046/1, BS 5000

**MTU Powered Sterling Gensets**

Sterling provides the range of MTU powered gensets which are recognized globally for reliability, better efficiency and eco-friendliness  
Gensets are designed and tested as per MTU guidelines  
Single window responsibility for Sales, Service and Spares  
Genset Warranty : Standard 1 year with Unlimited hours of operation

**Prime Power** : Variable load not exceeding 75%. Overload of 10% permitted for 1 hour in every 12 hour of operation

**Standby Power** : 85% load factor with a maximum of 500 hours running per year



**ISO 9001:2000**

# SGM-1875PH / 2050SH

## ENGINE TECHNICAL SPECIFICATIONS

Description	Units	50 HZ
<b>Manufacturer</b>		
Type		<b>MTU 12V4000G63</b>
Cylinder arrangement	Vee	Turbocharged, Air-to-Water cooling
Displacement	Liters	12
Bore and stroke	MM	57.2
Compression ratio	Ratio	170 X 210
Rated speed	RPM	16.5 : 1
Altitude capability above MSL	Mtrs	1500
Lube oil & filter change period	Hours	1500
Minimum continuous load	%	500
Piston speed	Mtrs/Sec	20
Engine kW at rated RPM	kW (HP)	10.5
Fuel stop power as per ISO-3046	kW (HP)	1575 kW (2111 HP)
Frequency regulation, steady state	%	1733 kW (2323 HP)
BMEP	kPa	+/- 0.25
Governor type	-	2200
Governor class	-	Electronic, Isochronous (Droop adjustable to 4%)
Engine overspeed shutdown	RPM	ISO 8528-5, better than Class G3
		1800
<b>Exhaust System</b>		
Exhaust gas flow	m3/min	270
Exhaust gas temperature	Deg C	440
Exhaust back pressure - Design value/Maximum	mbar	30/85
<b>Fuel System</b>		
Type of injection		CRDI with Electronic Unit Injection
Fuel supply flow - Max	LPM	12/5
Fuel temperature at fuel inlet - Max	Deg C	55
Fuel pressure at return - Max	Bar	0.5
Maximum suction head at pump inlet	Mtrs	2.5
Fuel filter filtration capacity - Secondary	Microns	5
Fuel filter pressure differential - Max	Bar	1
<b>Lube Oil System</b>		
Total system capacity	Litres	260
Normal lube oil pressure	Bar	6
Normal lube oil temperature	Deg C	88 - 98
Lube oil differential pressure	Bar	1.5
Lube oil filter filtration capacity	Microns	12
Recommended lube oil grade		API-C14
<b>Heat Balance @ 100% Load</b>		
Energy to coolant	kW	580
Energy to charge air cooler	kW	260
Energy to radiation	kW	75
<b>Combustion/Air Intake</b>		
Combustion air flow	m3/min	108
Charge air pressure	Bar	2.9
Air filter	Type	Dry paper type - 2 Nos.
<b>Coolant System</b>		
Total system capacity	Litres	400
Cooling sytem operating pressure	Bar	2.5
Normal Coolant temperature - HT/LT	Deg C	100/55
Coolant flow - HT/LT	m3/Hr	56/30
Coolant pump inlet pressure - Min/Max	Bar	0.5/1.5
Cooling system ambient capability	Deg C	50
Recommended coolant		MTU extended life coolant
<b>Engine Electrical System</b>		
Type		24V negative earth
Charging alternator volts / Current	VDC / Amps	28 / 70
Starter power	kW	2X9
Lube oil consumption	% of Fuel	0.3% of fuel consumption

# SGM-1875PH / 2050SH

## Genset Controllers

**SGDF-C2**



**SGDF-C3**



### SGDF-C2 : AMF Controller (Standard Supply)

**Features:**

- Auto Start /Stop.
- Local & Remote Start/Stop
- Engine Parameters Reading via CANBUS.
- Genset Breaker and Mains Breaker Control.
- Easily accessible.
- MODBUS for BMS connectivity.

**Display**

- Engine Parameters
- Running Status
- Event Recording
- Fault Code Display
- Hourmeter
- Voltage, Current, Hz, KW, KVA, Pf and KVAR
- Breaker Status
- Service Timer Indication
- Real Time Clock for Time and Date

**Protection**

- Under Voltage / Over Voltage
- Under Frequency / Over Frequency
- Reverse Power
- Over Current
- Engine Protections

### SGDF-C3 Automatic Genset Controller (Optional).

**Features:**

- AMF & Synchronising Controller
- Synchronising up to 16 Genset each with individual controller
- Momentarily Mains paralleling
- Auto load sharing
- Load dependent start /stop
- Load limiting Device
- Mains power export
- Simple Logic configuration tool
- Need based Priority change over / power management (Programmable)
- Genset Breaker and Mains Breaker Controller
- Auto Start / Stop
- Local & Remote Start/Stop
- Eng. parameters & protections reading via CAN bus
- Easy accessibility
- Modbus for BMS connectivity
- Utility software for PC interface
- Grid Paralleling (**SGDF-C4 mains Optional**)

**Display**

- Engine parameters
- Running Status
- Event Recording
- Fault Code display
- Service Timer Indication
- Hour Meter, Real Time Clock for time and Date
- Voltage, Current, Hz, KW, KVA, Pf and KVAR
- Breaker Status
- Synchronous Scope

**Protection**

- Engine Protections
- Under voltage / over voltage (27/59)
- Under frequency/ over frequency (81)
- Reverse power (active and re-active) (32)
- Over Current (2 Level) (51)
- Peak Current (50)
- Loss of excitation (40)
- Current unbalance (46)
- Voltage asymmetry (47)

# SGM-1875PH / 2050SH

Sterling Standard Scope of Supply	OPTIONALS
<b>Basic Engine</b> Cylinder block Flywheel housing - SAE 00 High inertia flywheel - SAE 21 Oil pan Forged crankshaft & connecting rods Valve rotators (Rotocap) Four-valve per cylinder, Individual cylinder head Aluminium Pistons Piston cooling via oil spray nozzle Dry exhaust manifolds Vibration damper Mounted air filter All necessary on-engine air, exhaust, coolant, fuel and oil pipework	<b>Engine</b> Jacket water heater - 110V/240V Lube oil heaters Dual electric starters Critical Silencers Additional Manuals
<b>Starting System</b> Electric starter, dual Battery charging alternator, V-belt driven - 28VDC, 100 A, 2 pole Battery, Battery stand & Leads Engine wiring harness and sensors	<b>Control Panel</b> Standard Breaker Panels Remote Annunciators AMF Panel Auto/Manual Synchronising Panel Auto Load Sharing/Load dependant Panel IP 54/55 Enclosure Isolator Panel Project Specific/Custom built Panels H T Panels for 1000 kVa & above ratings L T Distribution Boards PCC/MCC Panels PLC Panels
<b>Fuel System</b> CRDI fuel system with High and Low pressure pumps Electronically controlled fuel injection with high pressure lines Fuel pressure accumulator Fuel cooler Fuel priming pump for initial system filling and venting Engine standard version for fuel consumption-optimized operation Secondary Fuel Filter Fuel Water Separator	<b>Alternator</b> Space Heaters RTD/BTD with Scanners Oversized alternator IP 54/55 Enclosure HT Alternators - 1000 kVA & above PMG Differential CT mounted on alternator Different cooling options
<b>Lube Oil System</b> Forced-feed lubrication system with piston cooling Lube oil circulation pump with safety valve Lube oil multi-stage filter Lube oil heat exchanger Oil filler neck and oil dipstick for measurement on non-running engine Closed crankcase venting system	<b>Others</b> Cap Type Acoustic Enclosure Additional Spare Parts Manuals Additional O&M Manuals Ni-cad Starting Batteries & Chargers Fuel level sensors Lube Oil Priming Pump - Electric/Manual Heavy Duty Air Cleaners Soot Arrestors Exhaust Scrubbers Containerized Genset in 40 Feet Container Duplex fuel pre - filters Multi spring vibration Isolators
<b>Combustion Air System</b> Exhaust turbochargers with insulation Intercooler Exhaust flexible bellows - 2 nos. Exhaust Silencers - Residential Set of dry-type air filters with contamination indicator	
<b>Cooling System</b> Coolant circulation pump for jacket water and after cooler Coolant thermostat for jacket water cooling system Coolant thermostat for charge air cooling system Heat Exchanger - Plate type	
<b>Engine Mounting</b> Set of engine mounting brackets at engine free end and driving end Resilient engine mounts (Rubber Elements) on engine free end and driving end Alternator mounts (Rubber Elements)	<b>Genset Controllers</b> SGDF-C1 Controller - Digital display module SGDF-C3 Controller - Auto Sync Module SGDF-C4 Mains Controller - For Grid Paralleling PLC based load management system
<b>Genset Management System - SGDF-C2 (Supplied as standard)</b> Electronic controller for indicating genset parameters Emergency stop push button Genset monitoring and display of Engine-alternator operating parameters and alarms Genset protection against critical operating parameters - Automatic start sequence control - Acquisition and display of plant-related measuring data - Communication with an external system	
<b>Generator</b> 415 Volts, 50 HZ, 1500 RPM, 4 pole, Single BEARING, 3 phase connected with IP23 protection. Alternator conforms to IS-4722 or equivalent	
<b>Paintwork</b> Standard paintwork, single-coat, water-based	
<b>Documentation</b> Standard Factory test report Engine alternator test certificate Warranty certificate Set of standard operating and maintenance documentation & Spare parts manual	

# SGM-1875PH / 2050SH

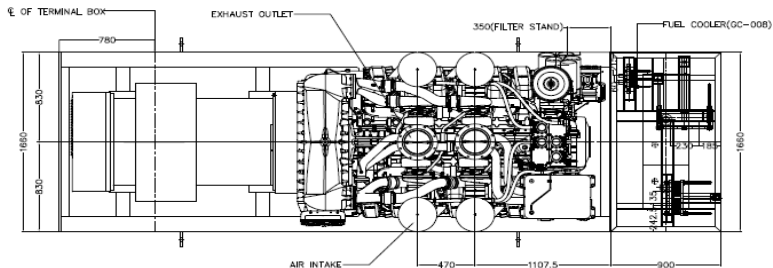

TOP VIEW

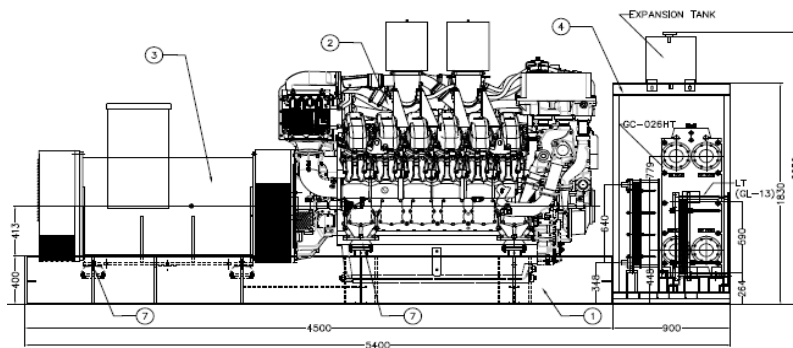

WEIGHT	13500 KG.(APPROX.)	
7	AVM	MTU/65
6	FILTER STAND	SGPL
5	FUEL PRE FILTER	SEPAR
4	HEAT EXCHANGER	TRANIER
3	ALTERNATOR	LSC 74L1
2	ENGINE	MTU 12V 4000 G63
1	BASE FRAME	SGPL
PART NO.	DESCRIPTION	MAKE/MODEL(1825 KVA)

### Acoustic Enclosure (Cap On Type)

### STD Open Generator

Length	9000	Length	5400
Width	3000	Width	1660
Height	4100	Height	2250
Total Weight in Kgs (Wet)	18000(apprx.)	Weight in Kgs (Wet)	13500(apprx.)

#### Head Quarters

Sterling & Wilson Powergen (P) Ltd.,  
8, Sundaram Estate  
Govandi Station Road  
Govandi East  
Mumbai - 400 088  
Tel : 022 - 2552 6100  
Fax : 022 - 2552 6200  
Website: www.sterlinggenerators.com

#### Works

Sterling Generators (P) Ltd.,  
Survey No. 59, 343/1  
Village kala, Kherdi, Khanvel  
Silvassa 396230  
U.T. of Dadra & Nagar Haveli  
Tel : 0260 - 2677408 / 419  
Fax : 0260 - 2677408  
E-Mail : silvassa@sterlinggenerators.com

#### Marketing & Support offices

Zonal Office - South	Zonal Office - North	Zonal Office - East	Zonal Office - West
Sterling & Wilson Powergen (P) Ltd., Sterling Towers, No. 4A/14, 4th Main Road, Chikka Adugodi New Layout Tavarekere Main Road, Bangalore - 560 029 Tel : 080 - 67178600 - 609 Fax : 080 - 67178675	Sterling & Wilson Powergen (P) Ltd., Sterling & Wilson House, C-56/38, Institutional Area, Sector 68, Noida - UP Tel : 0120 - 407 1000 Fax : 0120 - 407 1030	Sterling Generators (P) Ltd., BF - 164, Sector 1, Salt Lake City, Kolkata - 700 064 Tel : 033 - 2337 3933 Fax : 033 - 4005 5416	Sterling & Wilson Powergen (P) Ltd., 8, Sundaram Estate Govandi Station Road Govandi East Mumbai - 400 088 Tel : 022 - 2552 6100 Fax : 022 - 2552 6200

#### BRANCHES

Hyderabad Chennai Coimbatore	Jaipur Chandigarh	Bhubaneshwar	Baroda Pune
------------------------------------	----------------------	--------------	----------------

#### Authorized Dealer